

# Water Sensor

*Know when water invades your spaces*

## Detect Moisture

Each WeatherGoose Climate Monitor (except the MiniGoose) contains a three-port I/O connector, called the "C123C" port. Up to three individual water sensors can be attached to this port. If more sensors are needed, they can be wired in parallel and report as a group.

The I/O ports are supplied with a +5VDC supply voltage which senses whether water is present due to the change in conductivity in the water sensor.

The water sensor can show whether the sensor is dry, damp, or completely immersed in water. Increasing dampness will be shown as a downward trend in the graph as conductivity increases.

## Conductivity Bridge

The water sensors continuously measure the conductivity of the environment they are immersed in. In dry air, the reading should be about "99". When placed in a glass of tap water the reading should be around "50". Intermediate values show the conductivity increasing as the reading decreases.

The sensors connect to the WeatherGoose with 24 AWG solid copper wire. Runs of over 100 feet can be used.

## Prevent Sensor from Moving

Most sensors are mounted out of sight under flooring, in pipe closets, or in overhead water catch trays. If the cables are moved, there is a possibility of the sensor losing its most sensitive position or becoming airborne. Some users place bricks on their water sensors, but ITW recommends tie-wraps or epoxy glue to wooden brackets.

## Testing the Sensors

ITW recommends testing the water sensors to verify that the each water sensor sends an alarm and that the e-mail arrives at the proper address. Testing requires the sensor be immersed in a cup filled with water and the transmission of the alarm verified.

## Cable Length

Cable runs of 100' and over are common. Use 22 or 24 AWG solid wire for easy insertion into the C123C I/O ports.

**Model Number:** WD-1

Includes 15' of cable



*A water sensor shown with the metal water detectors pointed up. When installed, these metal brads must face down.*

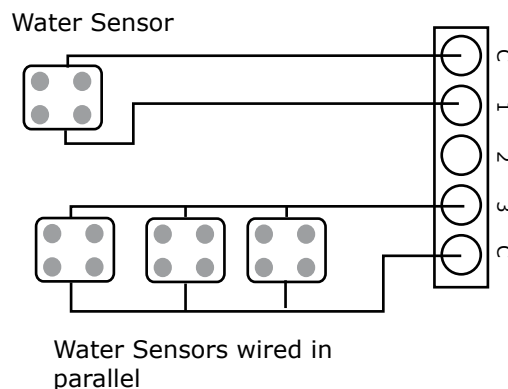

*Connect the sensors to the C123C block. "C" is common (ground). If more than three water sensors are to be used, they can be wired in parallel (not series). When wired in parallel, when any sensor becomes wet it will trip the alarm for that input.*

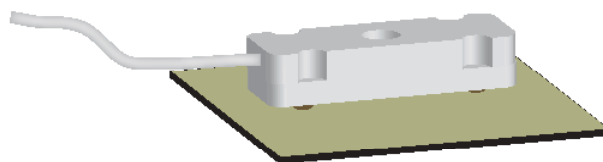

*When mounted in a metal tray, mount the sensor face down on an insulating surface such as a vinyl floor tile. Secure the sensor with tie wraps or wooden brackets.*

**ITWatchDogs.com** 

12885 Research Blvd. Suite 210B  
Austin, Texas 78750

512-257-1462