

# Current Transformer

*Measure 30, 60, or 120 amps*

## Clamps Around Existing Cable

Current transformers clamp around a single current-carrying wire and transform the amperage into a 0 to 5 VDC signal suitable for input into the I/O ports of a WeatherGoose Climate Monitor.

Each WeatherGoose Climate Monitor (except the MiniGoose) contains a three-port I/O connector, called the "C123C" port. Up to three individual current transformers can be attached to this port. If more are required, a CCAT serial bus interface can be added. Up to 16 CCATs can be added to the serial bus.

The current transformer uses swing-open jaws to clamp around a current carrying wire. Note that a single wire is necessary for current measurement. If two wires are placed in the transformer, their magnetic fields will cancel each other and the current measurement will not be accurate.

## Self-Powered, Linear Output

The transformer is manufactured by Flex-Core and further specifications are at: <http://www.flex-core.com>.

No power supply required; the transformer is parasitically powered from the line current.

The sensors connect to the WeatherGoose with 24 AWG solid copper wire. Runs of over 100 feet can be used.

The output is linear. Note that the current values displayed are 0 - 100 in the WeatherGoose. If a CCAT interface is used, a current range can be specified.

## Specifications

Amperage range: 30, 60, 120 amp, ac  
 Output: 0 - 5 VDC  
 Accuracy: +/- 2% from 10% to 100% full scale  
 Response time: 2 seconds  
 Size: 2.9" L x 2.58" W x 1.04" H  
 Wire opening: 1.1" L x .9" W  
 Approvals: UL listed E150462  
 Model Number: H922

## Cable Length

Cable runs of 100' and over are common. Use 22 or 24 AWG solid wire for easy insertion into the C123C I/O ports.

**Model Number:** CT-30/60/120  
 Includes 15' of cable



*A current transformer with switch selectable 30, 60, or 120 amp settings.*

Current Transformer

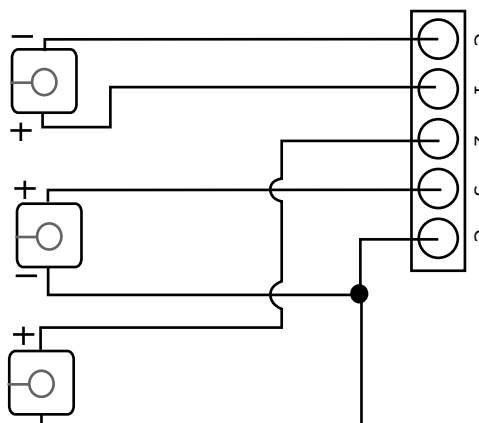

*Connect the sensors to the C123C block. Note polarity on current transformers.*



*The jaws swing open and a wire can be inserted.*

**ITWatchDogs.com** 

12885 Research Blvd. Suite 210B  
 Austin, Texas 78750

512-257-1462